

# V-35

Surface Generator



Compact 3-axis generator for all organic materials.

**satisloh**<sup>®</sup>



The 32 mm PCD cutter of the V-35 processes all organic materials at high speed

## Features and Benefits:

- Compact, ergonomic design:**  
 Easy table top mounting; produces a variety of lens curves with minimal space requirement.
- High speed and reliability:**  
 Excellent speed and productivity due to large PCD cutting tool. Robust construction for greater accuracy and reliability.
- Dry cutting accuracy:**  
 Prescriptions are generated free of elliptical error in a wide range from -30 up to +6 diopters.
- Easy to use touch screen:**  
 Integrated smart software provides directional assistance for even the most inexperienced operator. On-screen operations, maintenance and parts manuals can be accessed with the touch of a button.
- Complete lens processing:**  
 Surface generation, lens cribbing and pin-beveling in one process step.
- Lap tools:**  
 Processes plastic or foam laps to match surfaceable lens curves. Software suggests best lap to minimize waste and cutting time.
- Interfaceable and compatible:**  
 Fully interfaceable with most 3rd-party software packages. OMA protocol compatible.

## Technical Information:

- Power:**  
 115-230 V, 50/60 Hz, 20 A, 1500 W
- Dimensions (wxdxh):**  
 892 x 728 x 545 mm /  
 35.1 x 28.6 x 21.5 inches
- Weight:**  
 Generator: 54 kg / 120 lbs  
 Vacuum: 11 kg / 24 lbs
- Compressed air:**  
 7 bar / 100 PSI, 100 l/min
- Working ranges:**
  - High speed tool:**  
 Lens curve range: +6 to -20 dpt.  
 Lap curve range: -6 to +20 dpt.
  - High range tool:**  
 Lens curve range: +6 to -30 dpt.  
 Lap curve range: -6 to +30 dpt.
  - Cylinder range:** 15 dpt.
  - Prism range:** 15 dpt.
  - Saddleback range:** +6 to -6 dpt.
  - Maximum blank size:**  
 90 mm (blocked on geometric center)

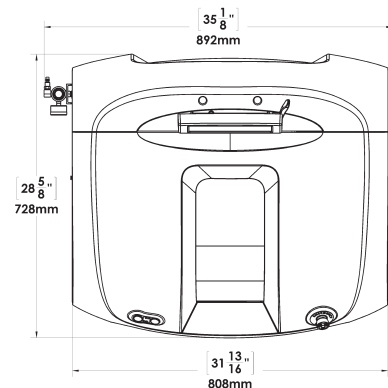

© Satisloh / KH / June 2009  
 Subject to technical changes

# Contact

**Satisloh AG**  
 Neuhofstrasse 12  
 CH - 6340 Baar  
 Switzerland  
 Phone: +41 (0) 41766 16 16  
 Fax: +41 (0) 41766 16 10  
 Mail: info@satisloh.com

www.satisloh.com

### North America

**Sales**  
 Phone: +1 262 255 6001  
 Email: info.usa@satisloh.com

**Service**  
 Phone: +1 262 255 6001  
 Email: service.usa@satisloh.com

### Europe

Phone: +49 (0) 6441 912 0  
 Email: info.de@satisloh.com

Phone: +49 (0) 6441 912 222  
 Email: service.de@satisloh.com

### Asia

Phone: +852 27 56 7711  
 Email: info.asia@satisloh.com

Phone: +852 2756 7654  
 Email: service.asia@satisloh.com

**satisloh**®

